

SKU: NIM033SS00

NIM033BK00

NIM033WH00

newair[®]

Portable Countertop Ice Maker



OWNER'S MANUAL

Read and save these instructions.



Intertek

Manual v1.1

READ AND SAVE THESE INSTRUCTIONS.

TABLE OF CONTENTS

Register Your Product Online.....	3
Safety Information & Warnings	4
Getting To Know Your Ice Maker	7
Operating Procedures.....	8
Cleaning & Maintenance.....	10
Electrical Schematic Diagram.....	11
Troubleshooting.....	11
Limited Manufacturer's Warranty	12

SPECIFICATIONS

MODEL No.	NIM033WH00/NIM033BK00/NIM033SS00
VOLTAGE:	110-120V
CURRENT:	1.75A
FREQUENCY:	50-60Hz
REFRIGERANT:	R134a/1.23 oz
NET WEIGHT:	18.7 lbs
DIMENSIONS:	14.10" D x 9.60" W x 11.70" H
CERTIFICATIONS:	ETL

REGISTER YOUR PRODUCT ONLINE

Register Your Pepsi Product Online Today!

Take advantage of all the benefits product registration has to offer:



Service and Support

Diagnose troubleshooting and service issues faster and more accurately



Recall Notifications

Stay up-to-date on safety, system updates, and recall notifications



Special Promotions

Opt-in for NewAir promotions and offers

Registering your product information online is safe & secure and takes less than 2 minutes to complete:

newair.com/register

Alternatively, we recommend you attach a copy of your sales receipt below and record the following information, located on the manufacturer's nameplate on the rear of the unit. You will need this information if it becomes necessary to contact the manufacturer for service inquiries.

Date of Purchase: _____

Serial Number: _____

Model Number: _____

SAFETY INFORMATION & WARNINGS

Please read the following instructions carefully before using this ice maker and keep this user manual for future reference. Safety precautions must be followed. Failure to obey the safety precautions will result in possible harm to you and will void the manufacturer's warranty. In order to prevent any hazards, please follow all safety precautions.



WHEN USING ELECTRICAL APPLIANCES, BASIC SAFETY PRECAUTIONS SHOULD BE FOLLOWED TO REDUCE THE RISK OF FIRE, ELECTRIC SHOCK, AND INJURY TO PERSONS OR PROPERTY. READ ALL INSTRUCTIONS BEFORE USING THIS ICE MAKER.

- This appliance should only be used by children that are eight years old and above or persons with reduced physical, sensory, or mental capabilities, or lack of experience and knowledge, if they have been given supervision or instruction concerning use of the appliance in a safe way and understand the hazards involved. Children must not play with the appliance. Cleaning and user maintenance should not be done by children without supervision.
- Do not place hands or objects on or near the ice maker's evaporator when it is in operation.
- Do not operate the appliance if the cord is damaged. If the supply cord is damaged, it must be replaced by the manufacturer in order to avoid a hazard.
- Connect the ice maker to proper outlets only. There should be no other appliance plugged into the same outlet. Be sure that the plug is fully inserted into the outlet.
- Do not run the cord over carpeting or other heat insulators. Do not cover the cord. Keep the cord away from traffic areas and do not submerge in water.
- Unplug the ice maker before cleaning or making repairs.
- Exercise caution and use reasonable supervision when the appliance is used near children.
- Do not clean your ice maker with flammable fluids. The fumes can create a fire hazard or explosion.
- Do not tip over.

- If the unit is stored in a very cold environment, allow it to warm to room temperature before use.
- Fill with potable water only.
- **Do not store explosive substances, such as aerosol cans with a flammable propellant, in this appliance.**
- This appliance is intended to be used in household and similar applications, such as staff kitchen areas in shops, offices, and other working environments; farm houses and by clients in hotels, motels, and other residential type environments; bed and breakfast type environments; catering and similar non-retail applications.
- Before using this product, place it on a flat surface.
- Please keep the ice maker running for 24 hours after receiving and first turning on the machine.
- Please make sure that the rear drain is firmly plugged before adding water to the water tank.
- The ice cubes produced will be relatively small at first. Do not be concerned as this is not a defect. The unit will take a few cycles to produce the intended size.
- Do not use near heat or excessive dust.
- Do not immerse the machine in water or use it in the bathroom or places where the machine may be splashed with water.
- Do not dismantle or modify the machine.
- If a problem occurs, stop using the machine immediately.
- Do not touch any of the parts involved in making the ice, and leave the lid closed while the ice is being produced.
- Please pull out the plug by holding the head of the plug. Never pull by the cord.
- Please periodically clean the dust off the plug head.
- Do not plug in the unit's power cord when your hands are wet.
- Disconnect the power supply and drain out the remaining water from the rear drain when the ice machine will not be used for an extended period of time.
- The ice cubes of the first cycle may have an odor due to water quality. This is not a defect. After several cycles, the smell will disappear. We suggest you

use an ice maker cleaning agent or citric acid to clean it before you use.
Please do not consume any ice cubes with an odor.

- Do not damage the cooling circuit (the piping).
- Do not damage the power cord or the power plug.
- Do not use damaged power plugs or loose sockets.
- Please don't repair or fix a broken power cord by yourself. If the power cord is damaged, please contact customer service.

GETTING TO KNOW YOUR ICE MAKER



1. **Ice Basket and Scoop:** used for storing and serving the ice.
2. **Windowed Cover:** allows you to check how much ice has been produced without having to open the top and let in warm air.
3. **Air Vents:** Located on the back and sides of the unit, these vents help prevent the unit from overheating. Please leave at least six inches of space all around the unit for proper ventilation.
4. **Water Drain:** allows you to empty the water from the tank easily.
5. **Max Fill Line:** Inside the water tank below the ice tray is a line marking labeled "MAX." Do not fill the water tank above this line.
6. **Controls/Indicator Lights:**
 - **ON/OFF:** Turn the unit on and off. While on, the unit will continuously produce ice, as long as there is water in the tank and the ice tray is not full.
 - **SELECT:** Select the size of the ice. Small ice takes roughly 6 minutes for a batch to complete, and large ice takes roughly 8 minutes for a batch to complete.
 - **ICE FULL:** There is an infrared sensor that helps detect when the ice tray is full. When the tray is full, ice production will stop and the "Ice Full" indicator will light up.
 - **ADD WATER:** When the "Add Water" indicator lights up, the unit will need more water poured into the water tray below the ice basket.

OPERATING PROCEDURES

UNPACKING YOUR ICE MAKER

1. Remove all exterior and interior packaging. Make sure that the ice basket and ice scoop are included. If any part or accessory is missing, please contact customer service.
2. Clean the interior with lukewarm water and a soft cloth. Remove the ice basket and wash it in warm water.
3. While the unit is still not plugged in, clean the evaporator rods using a water/vinegar solution.
4. Find a location for your ice maker that is protected from direct sunlight and allows for six inches of space between the back and sides of the ice maker and the wall.

CONNECTING YOUR ICE MAKER



Improper use of the grounded plug can result in the risk of electrical shock. If the power cord is damaged, please do not attempt to use the unit. Contact customer service, and we will

help you take care of the issue.

1. This unit should be properly grounded for your safety.
2. Plug the appliance directly into an appropriate 120V AC outlet that is properly installed and grounded in accordance with all local codes and ordinances.

USING YOUR ICE MAKER

1. Press the “ON/OFF” button after plugging in the ice maker and it will begin to run.
2. Open the cover, remove the ice basket, and pour water into the tank. Make sure it does not surpass the maximum water level. Place the ice basket back into the unit and close the lid.

3. While the ice maker is on, check the water level periodically. If the water pump cannot inject water, the ice maker will stop automatically, and the "ADD WATER" indicator will light up. Press the "ON/OFF" button to turn off the unit, fill water up to the "MAX" line, and press the "ON/OFF" button again to resume ice production.
4. The ice maker automatically stops working when the ice basket is full. The "ICE FULL" indicator will light up once it's full. To restart ice production, remove the ice from the tray and press "ON/OFF" again.
5. Change the water in the tank every 24 hours to ensure a reasonable hygiene level. If the unit is not in use for a few days, drain all the water in the tank reservoir and refill before operating again.

CLEANING & MAINTENANCE

Before using your ice maker, it is strongly recommended that you clean it thoroughly.

1. Remove the ice basket.
2. Turn the drain cap to drain out any water left in the tank.
3. Clean the interior with diluted detergent, warm water, and a soft cloth.
4. The outside of the ice maker should be cleaned regularly with a diluted detergent and warm water.
5. Dry the interior and exterior with a soft cloth.
6. Close the drain cap.

ELECTRICAL SCHEMATIC DIAGRAM

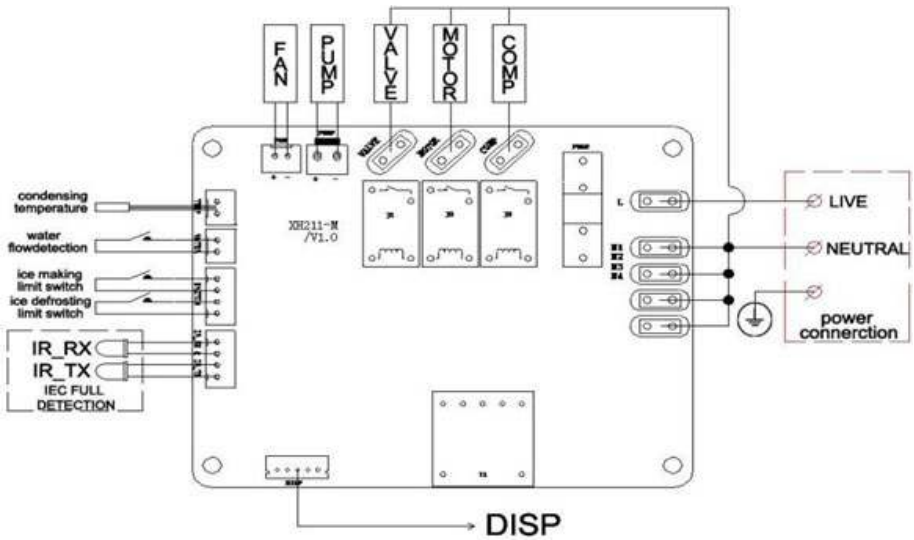

TROUBLESHOOTING

Problem	Possible Causes	Solution
“ADD WATER” indicator is on.	Water level is low.	Press “ON/OFF,” fill the water tank, and press “ON/OFF” again.
“ICE FULL” indicator is on.	The ice basket is full.	Remove ice from the basket.
	The ice sensor is broken.	Press “ON/OFF” to see if ice production restarts. If not, contact customer service.
	The ice scoop is stuck.	Check if ice is blocking the ice scoop and remove the ice.
Ice cubes stick together.	The ice making cycle is too long.	Stop the ice maker and restart when the current ice blocks melt and fall off. Turn the unit back on.
	Part of the evaporator rods in the ice box are too large.	Change the water in the reservoir.
	The water temperature in the inner tank is too low.	Use colder water to fill the tank.
Ice is full but the light is off.	The location of the ice maker’s light is too strong, and it effects the infrared detection.	Move the ice maker near a darker location.
Ice making cycle is normal but there is no ice.	Ambient temperature or water temperature is too high.	Try to keep the ice maker out of heat near 90 degrees, and fill the tank with cold water.
	Refrigerant liquid leakage.	Contact customer service.
	The pipe in the cooling system is blocked.	Contact customer service.

NOTE: Certain noises are normal when operating this ice maker: a clicking sound when the machine is turned on or off, a bubbling, gurgling, or knocking sound when refrigerant is circulating through the pipes, or a loud clink sound when ice cubes are dropped into the basket.

LIMITED MANUFACTURER'S WARRANTY

This appliance is covered by a limited manufacturer's warranty. For one year from the original date of purchase, the manufacturer will repair or replace any parts of this appliance that prove to be defective in materials and workmanship, provided the appliance has been used under normal operating conditions as intended by the manufacturer.

Warranty Terms:

During the first year, any components of this appliance found to be defective due to materials or workmanship will be repaired or replaced, at the manufacturer's discretion, at no charge to the original purchaser. The purchaser will be responsible for any removal or transportation costs.

Warranty Exclusions:

The warranty will not apply if damage is caused by any of the following:

- Power failure
- Damage in transit or when moving the appliance
- Improper power supply such as low voltage, defective household wiring or inadequate fuses
- Accident, alteration, misuse or abuse of the appliance such as using non-approved accessories, inadequate air circulation in the room or abnormal operating conditions (extreme temperatures)
- Use in commercial or industrial applications
- Fire, water damage, theft, war, riot, hostility or acts of God such as hurricanes, floods, etc.
- Use of force or damage caused by external influences
- Partially or completely dismantled appliances
- Excess wear and tear by the user

Obtaining Service:

When making a warranty claim, please have the original bill of purchase with purchase date available. Once confirmed that your appliance is eligible for warranty service, all repairs will be performed by a NewAir™ authorized repair facility. The purchaser will be responsible for any removal or transportation costs. Replacement parts and/or units will be new, remanufactured or refurbished and is subject to the manufacturer's discretion. For technical support and warranty service, please email support@newair.com